



INDEX Technical Data Sheet

2	OL 420 CS	10	OL 2200 CS
3	OL 560 CS	11	OL 2700 CS
4	OL 700 CS	12	OL 3200 CS
5	OL 900 CS	13	OL 3700 CS
6	OL 1100 CS	14	OL 4200 CS
7	OL 1300 CS	15	OL 5500 CS
8	OL 1600 CS	16	OL 6200 CS
9	OL 1900 CS			

OL 420 CS



TECHNICAL DATA

MODEL OL 420 CS		
Clamping force	kN	4.360
Clamping force	Ton	445
Injection force with 20 bar counterpressure	kN	417
Ejection force	kN	246
Max. die height	mm	700
Min. die height	mm	250
Platens dimensions (HxV)	mm	970x970
Tie bar spacing	mm	620x620
Tie bar diameter	mm	130
Movable platen stroke	mm	600
Ejection stroke	mm	140
Max. shot weight (Al alloy)	kg	4
Max. projected area (400 bar on metal)	cm ²	1.112
Dry Cycles (as per DIN 24480)	n/1'	3.5
Pumps motors power	KW	30
Machine weight	Ton	18
Machine dimensions (LxWxH)	m	6.9x3.1x3.0

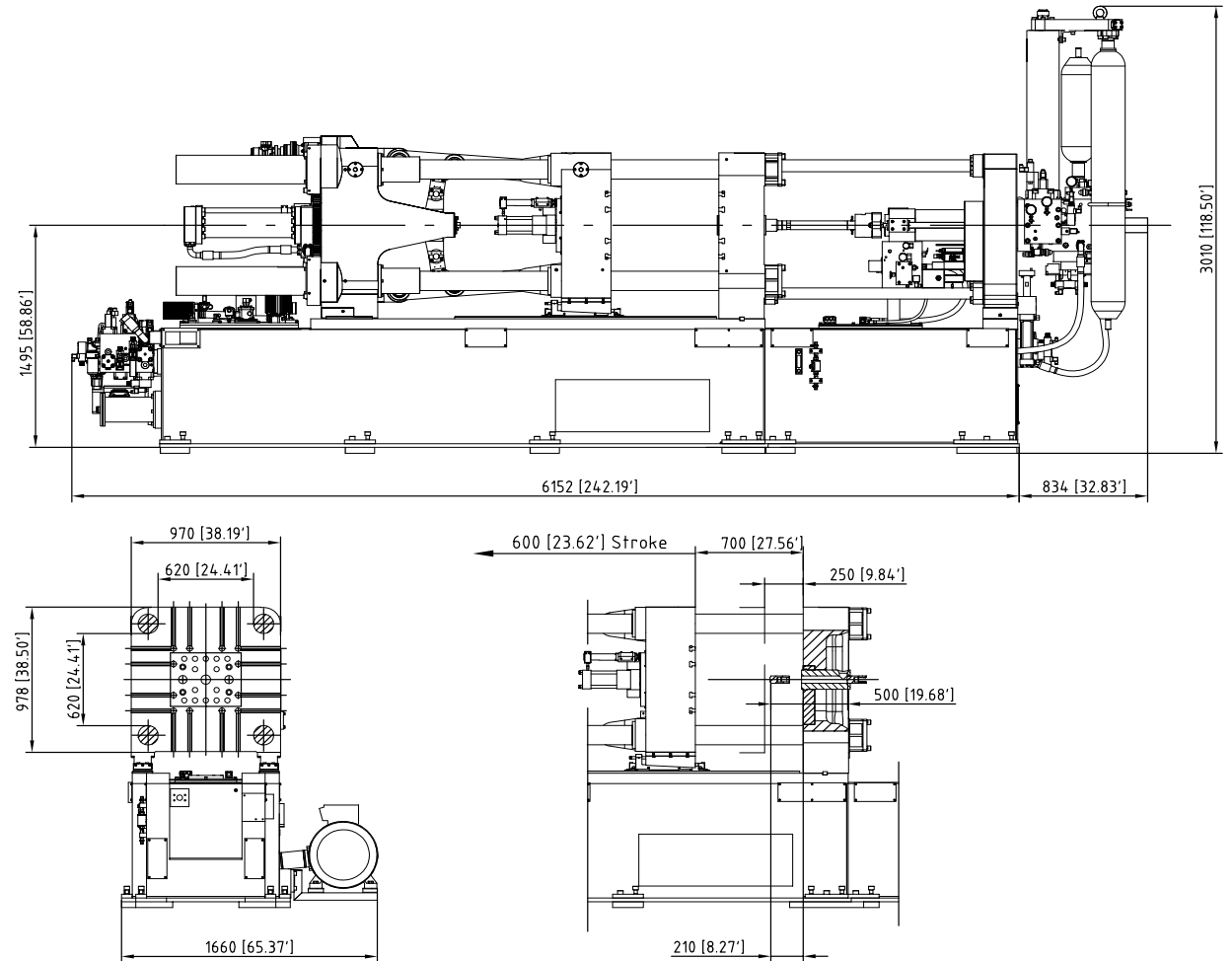

OL 560 CS



MODEL OL 560 CS

Clamping force	kN	5.850
Clamping force	Ton	597
Injection force with 20 bar counterpressure	kN	483
Ejection force	kN	246
Max. die height	mm	800
Min. die height	mm	300
Platens dimensions (HxV)	mm	1160x1160
Tie bar spacing	mm	760x760
Tie bar diameter	mm	140
Movable platen stroke	mm	700
Ejection stroke	mm	165
Max. shot weight (Al alloy)	kg	6
Max. projected area (400 bar on metal)	cm ²	1.491
Dry Cycles (as per DIN 24480)	n/1'	3.0
Pumps motors power	KW	37
Machine weight	Ton	24
Machine dimensions (LxWxH)	m	7.6x3.4x3.1

TECHNICAL DATA

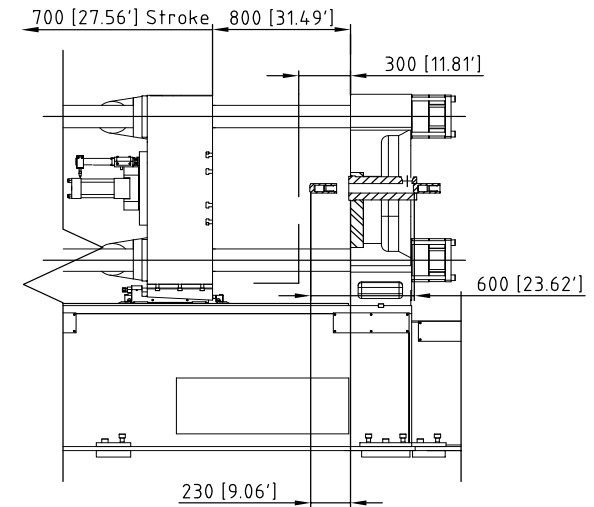
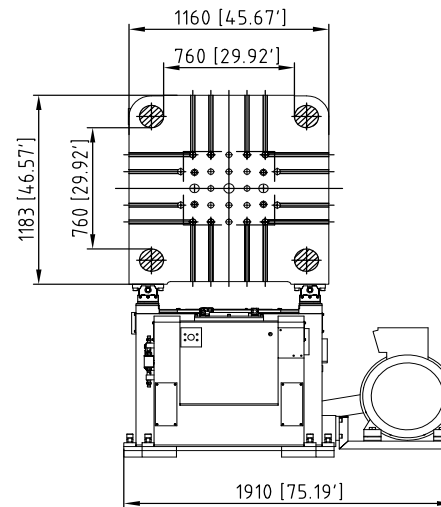
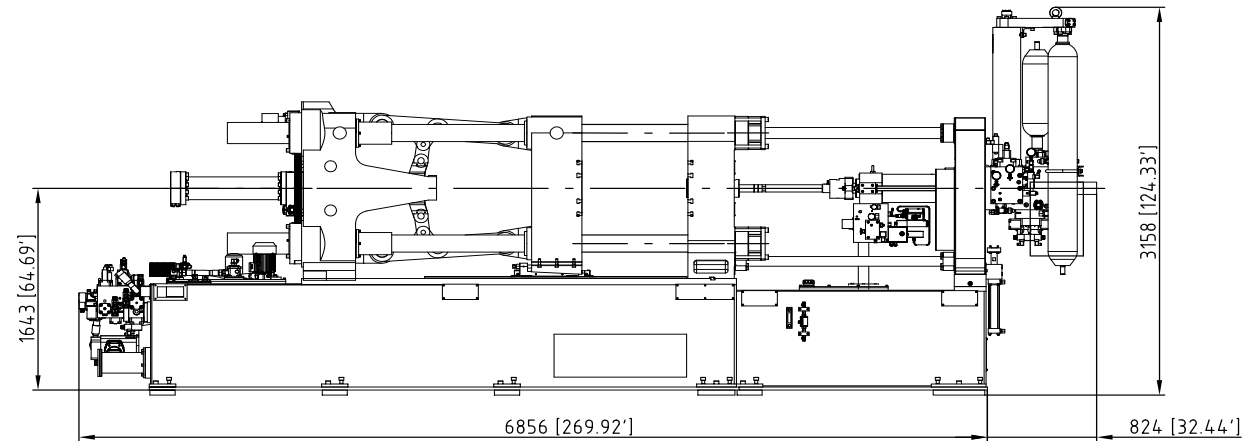

OL 700 CS



MODEL OL 700 CS

Clamping force	kN	7.500
Clamping force	Ton	765
Injection force with 20 bar counterpressure	kN	550
Ejection force	kN	385
Max. die height	mm	900
Min. die height	mm	400
Platens dimensions (HxV)	mm	1300x1300
Tie bar spacing	mm	840x840
Tie bar diameter	mm	165
Movable platen stroke	mm	780
Ejection stroke	mm	175
Max. shot weight (Al alloy)	kg	9
Max. projected area (400 bar on metal)	cm ²	1.912
Dry Cycles (as per DIN 24480)	n/1'	2.9
Pumps motors power	KW	45
Machine weight	Ton	33
Machine dimensions (LxWxH)	m	8.1x3.4x3.2

TECHNICAL DATA

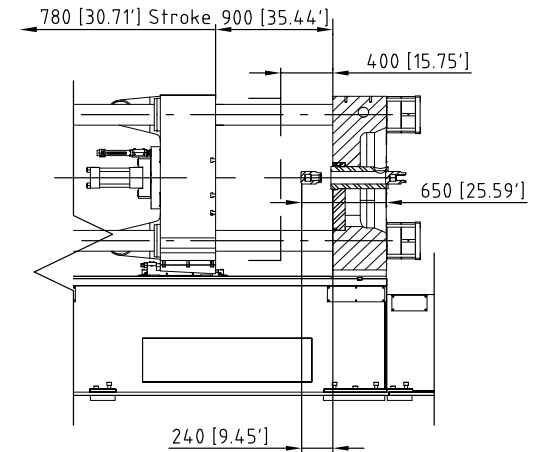
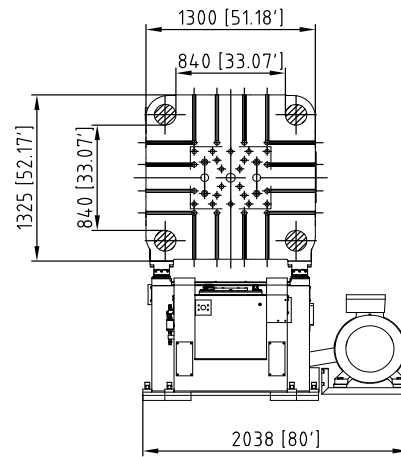
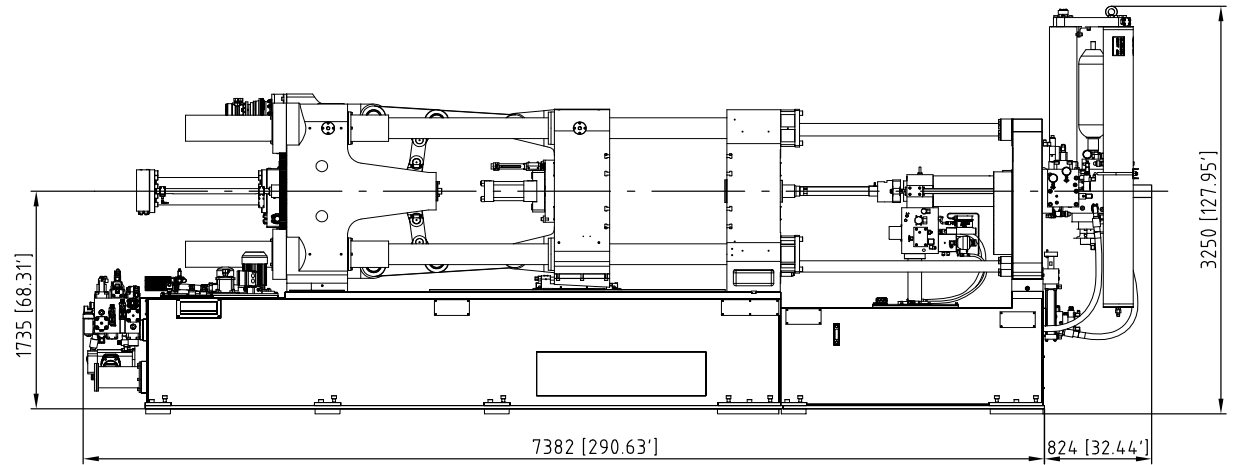

OL 900 CS



MODEL OL 900 CS

Clamping force	kN	9.200
Clamping force	Ton	938
Injection force with 20 bar counterpressure	kN	728
Ejection force	kN	385
Max. die height	mm	1.000
Min. die height	mm	450
Platens dimensions (HxV)	mm	1400x1400
Tie bar spacing	mm	910x910
Tie bar diameter	mm	180
Movable platen stroke	mm	900
Ejection stroke	mm	200
Max. shot weight (Al alloy)	kg	13
Max. projected area (400 bar on metal)	cm ²	2.346
Dry Cycles (as per DIN 24480)	n/1'	2.7
Pumps motors power	KW	45
Machine weight	Ton	47
Machine dimensions (LxWxH)	m	9.0x3.7x3.8

TECHNICAL DATA

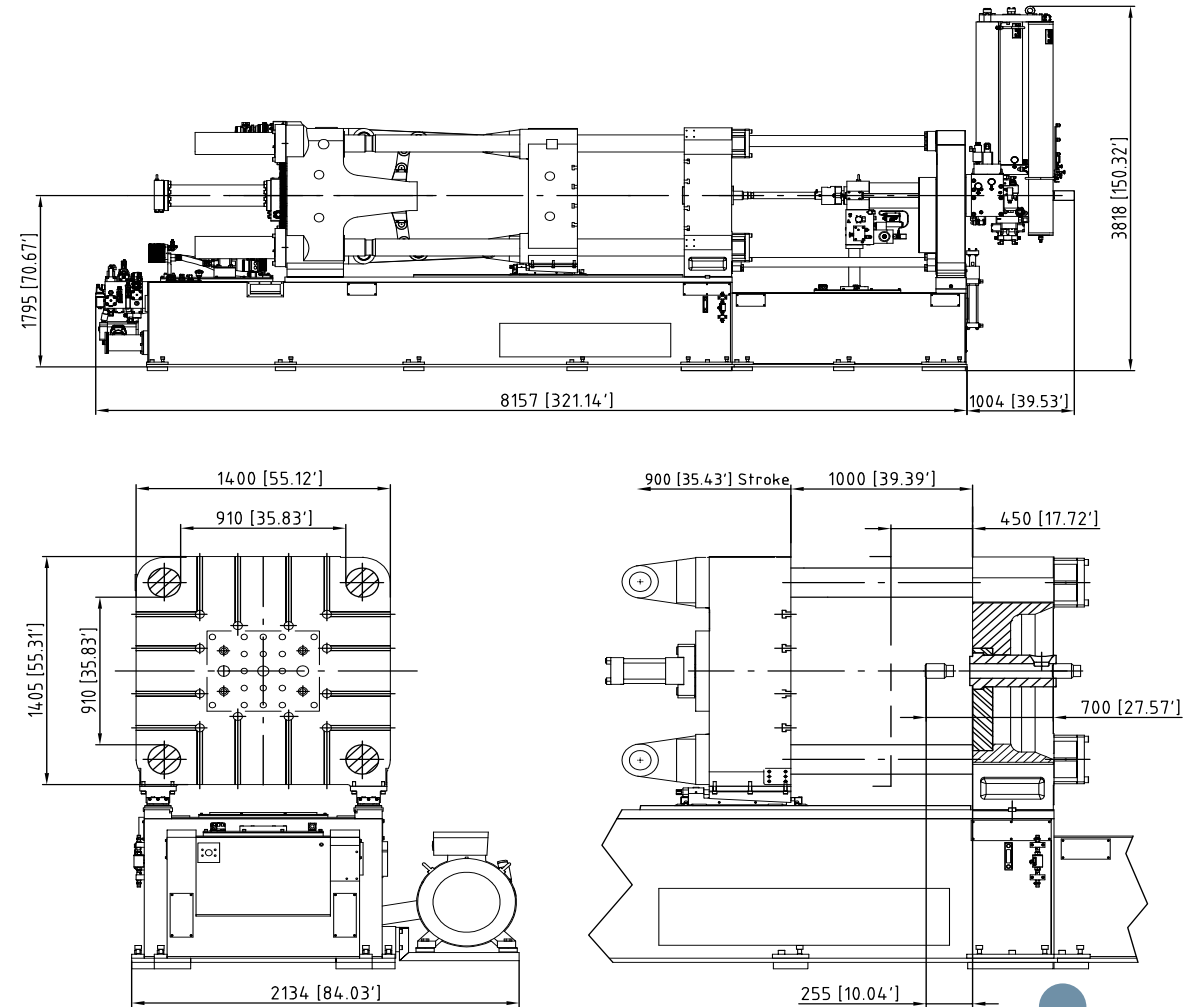

OL 1100 CS



MODEL OL 1100 CS

Clamping force	kN	11.000
Clamping force	Ton	1.122
Injection force with 20 bar counterpressure	kN	828
Ejection force	kN	483
Max. die height	mm	1.050
Min. die height	mm	450
Platens dimensions (HxV)	mm	1620x1620
Tie bar spacing	mm	1000x1000
Tie bar diameter	mm	200
Movable platen stroke	mm	960
Ejection stroke	mm	230
Max. shot weight (Al alloy)	kg	17
Max. projected area (400 bar on metal)	cm ²	2.804
Dry Cycles (as per DIN 24480)	n/1'	2.5
Pumps motors power	KW	55
Machine weight	Ton	56
Machine dimensions (LxWxH)	m	9.6x3.9x4.2

TECHNICAL DATA

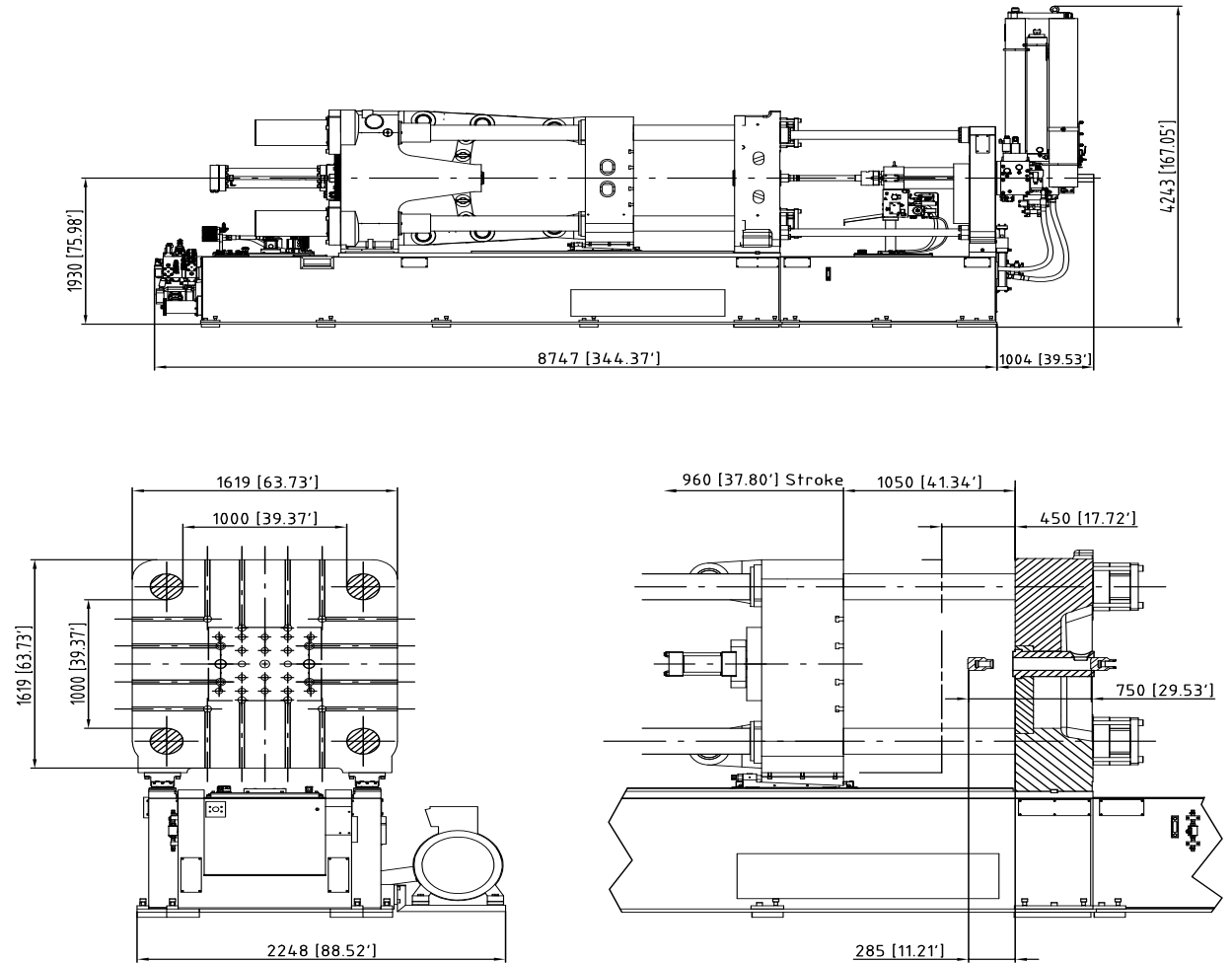

OL 1300 CS

MODEL OL 1300 CS

Clamping force	kN	13.250
Clamping force	Ton	1.351
Injection force with 20 bar counterpressure	kN	976
Ejection force	kN	630
Max. die height	mm	1.100
Min. die height	mm	450
Platens dimensions (HxV)	mm	1730x1730
Tie bar spacing	mm	1100x1100
Tie bar diameter	mm	215
Movable platen stroke	mm	1.070
Ejection stroke	mm	255
Max. shot weight (Al alloy)	kg	19
Max. projected area (400 bar on metal)	cm ²	3.377
Dry Cycles (as per DIN 24480)	n/1'	2.5
Pumps motors power	KW	2x37
Machine weight	Ton	65
Machine dimensions (LxWxH)	m	10.3x3.7x4.0

TECHNICAL DATA

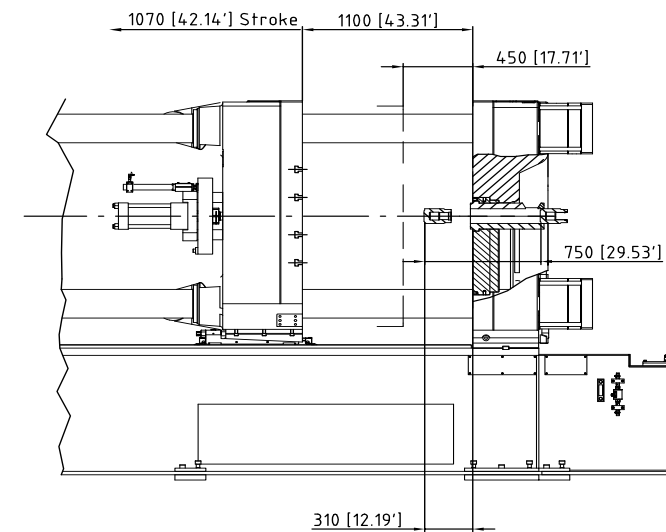
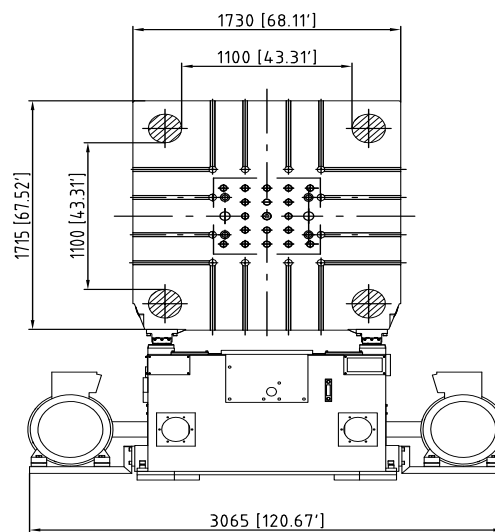
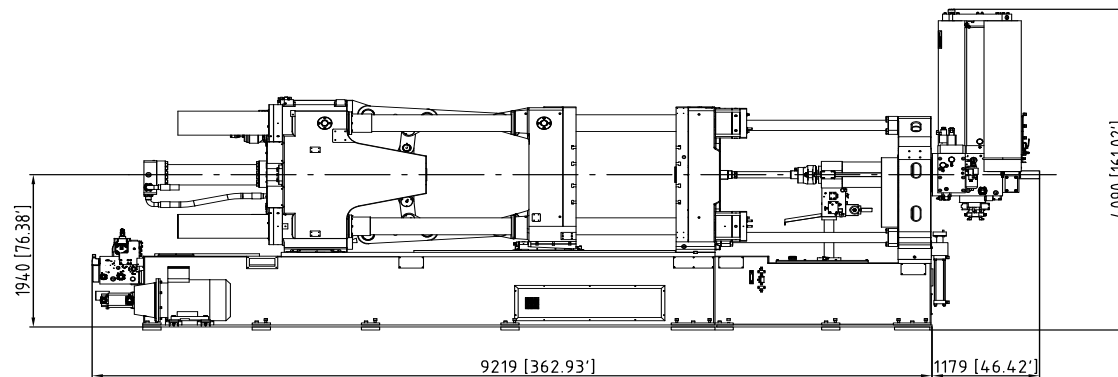

OL 1600 CS



MODEL OL 1600 CS

Clamping force	kN	17.100
Clamping force	Ton	1.743
Injection force with 20 bar counterpressure	kN	1.080
Ejection force	kN	630
Max. die height	mm	1.200
Min. die height	mm	450
Platens dimensions (HxV)	mm	1850x1850
Tie bar spacing	mm	1160x1160
Tie bar diameter	mm	240
Movable platen stroke	mm	1.200
Ejection stroke	mm	255
Max. shot weight (Al alloy)	kg	21
Max. projected area (400 bar on metal)	cm ²	4.358
Dry Cycles (as per DIN 24480)	n/1'	2.2
Pumps motors power	KW	2x37
Machine weight	Ton	85
Machine dimensions (LxWxH)	m	10.8x4.1x4.2

TECHNICAL DATA

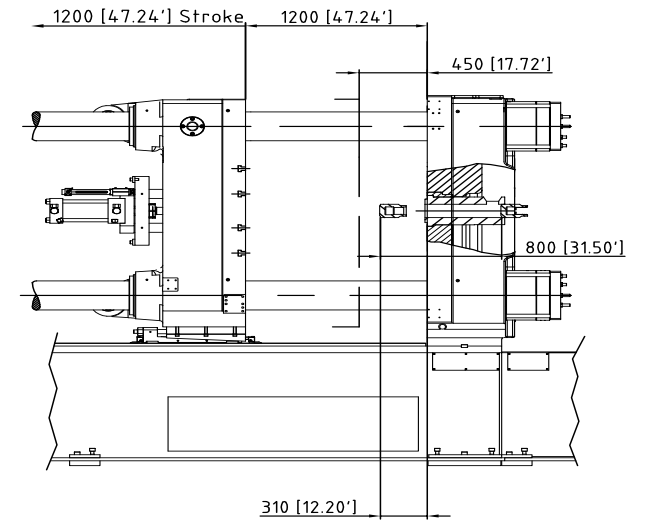
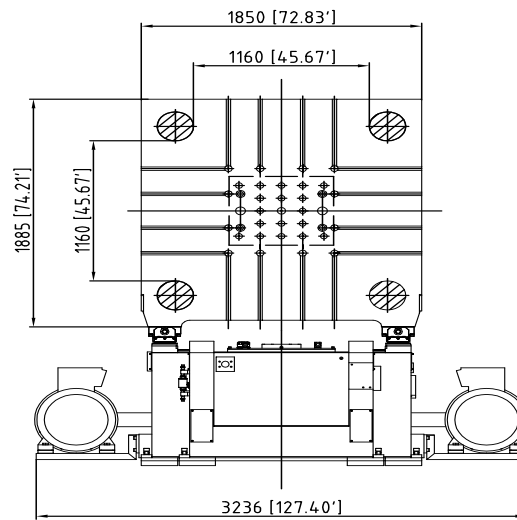
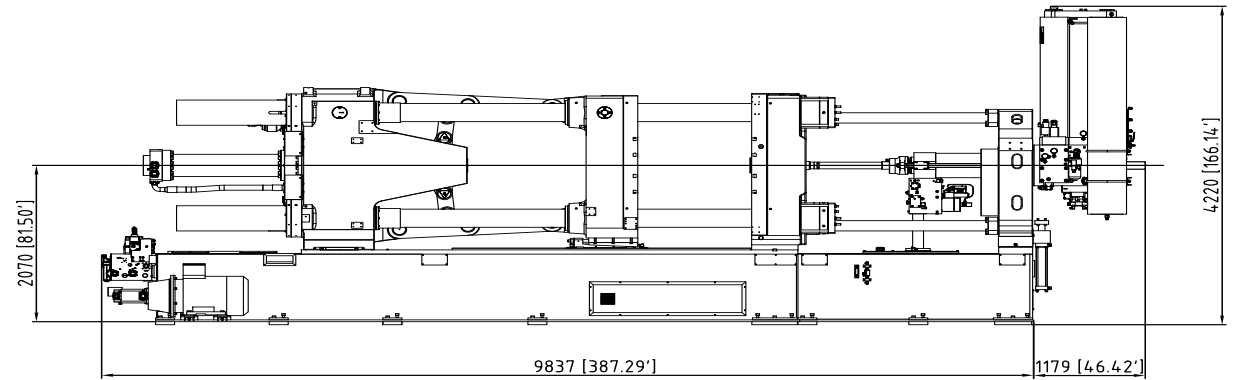

OL 1900 CS



MODEL OL 1900 CS

Clamping force	kN	19.600
Clamping force	Ton	1.998
Injection force with 20 bar counterpressure	kN	1.210
Ejection force	kN	688
Max. die height	mm	1.450
Min. die height	mm	600
Platens dimensions (HxV)	mm	1960x1960
Tie bar spacing	mm	1250x1250
Tie bar diameter	mm	250
Movable platen stroke	mm	1.400
Ejection stroke	mm	280
Max. shot weight (Al alloy)	kg	28
Max. projected area (400 bar on metal)	cm ²	4.995
Dry Cycles (as per DIN 24480)	n/1'	2.1
Pumps motors power	KW	2x45
Machine weight	Ton	98
Machine dimensions (LxWxH)	m	11.7x4.2x4.4

TECHNICAL DATA

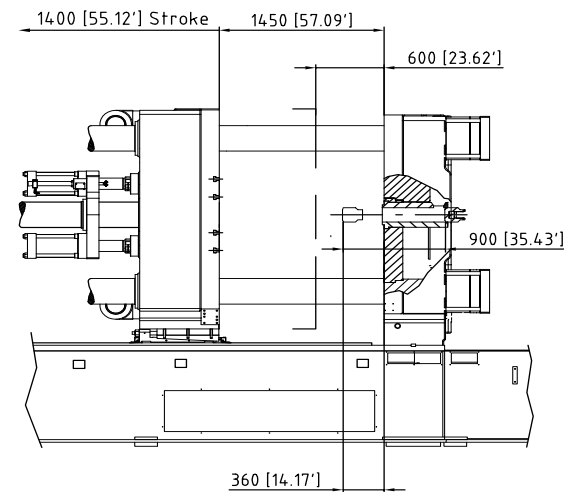
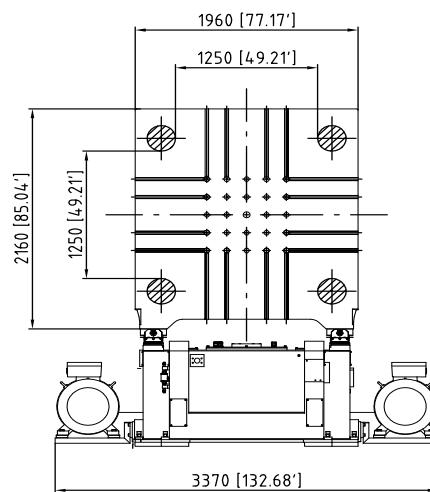
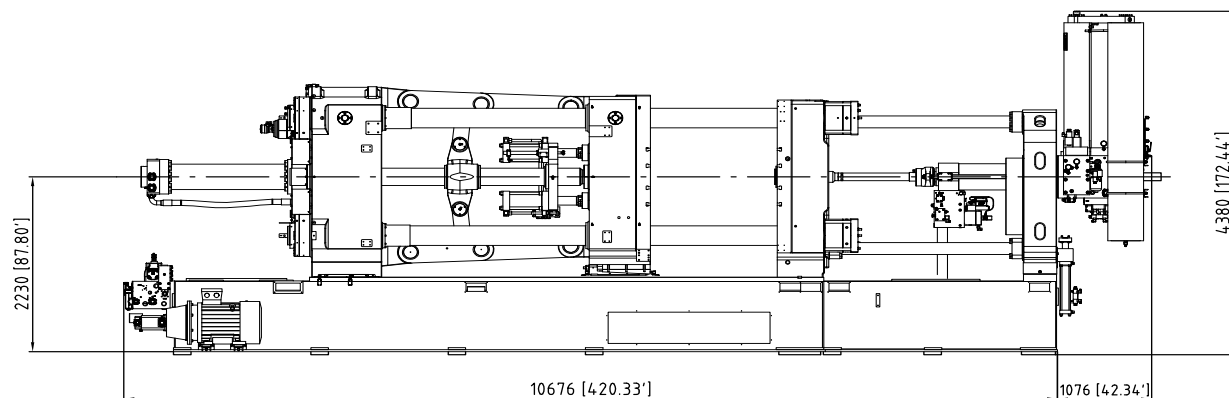

OL 2200 CS



MODEL OL 2200 CS

Clamping force	kN	23.000
Clamping force	Ton	2.345
Injection force with 20 bar counterpressure	kN	1.354
Ejection force	kN	688
Max. die height	mm	1.550
Min. die height	mm	720
Platens dimensions (HxV)	mm	2120x2120
Tie bar spacing	mm	1345x1345
Tie bar diameter	mm	280
Movable platen stroke	mm	1.400
Ejection stroke	mm	280
Max. shot weight (Al alloy)	kg	36
Max. projected area (400 bar on metal)	cm ²	5.861
Dry Cycles (as per DIN 24480)	n/1'	1.9
Pumps motors power	KW	2x55
Machine weight	Ton	113
Machine dimensions (LxWxH)	m	12.2x4.5x4.9

TECHNICAL DATA

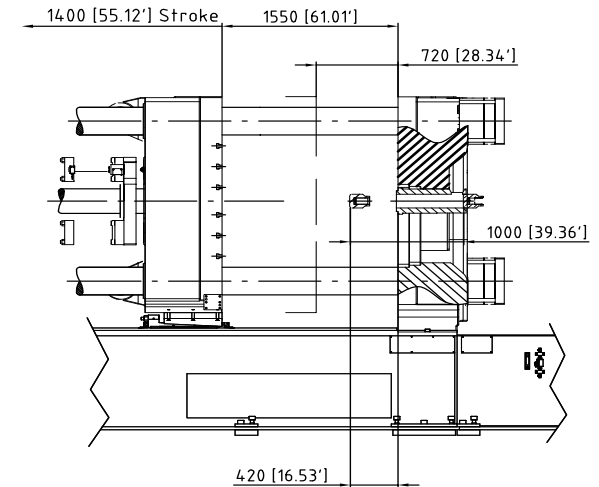
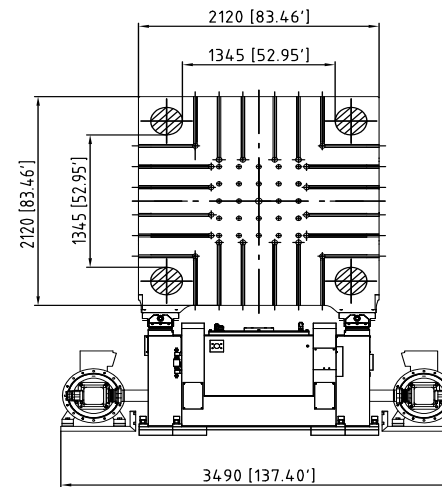
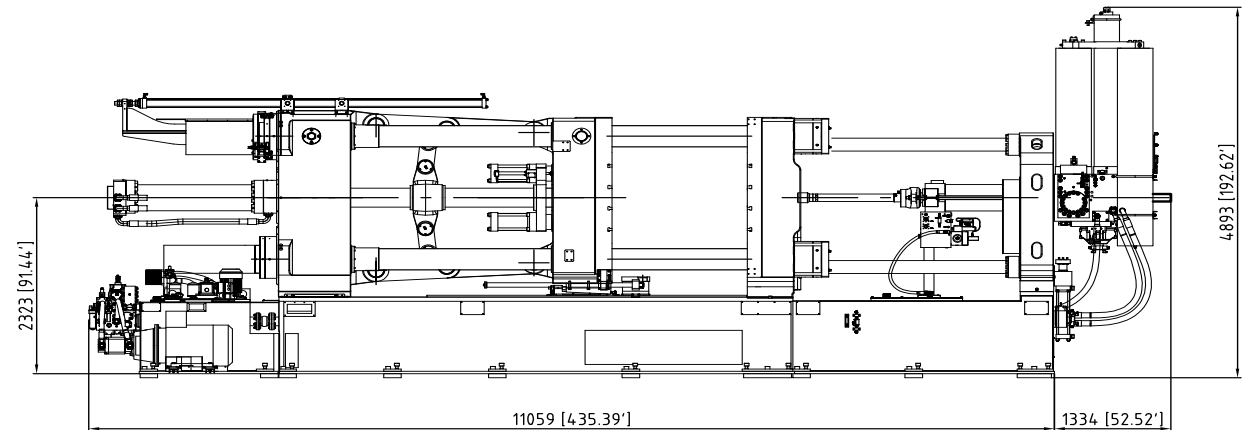

OL 2700 CS



MODEL OL 2700 CS

Clamping force	kN	28.100
Clamping force	Ton	2.864
Injection force with 20 bar counterpressure	kN	1.731
Ejection force	kN	786
Max. die height	mm	1.750
Min. die height	mm	800
Platens dimensions (HxV)	mm	2380x2380
Tie bar spacing	mm	1500x1500
Tie bar diameter	mm	300
Movable platen stroke	mm	1.500
Ejection stroke	mm	350
Max. shot weight (Al alloy)	kg	42
Max. projected area (400 bar on metal)	cm ²	7.161
Dry Cycles (as per DIN 24480)	n/1'	1.7
Pumps motors power	KW	2x55
Machine weight	Ton	150
Machine dimensions (LxWxH)	m	12.7x5.4x5.1

TECHNICAL DATA

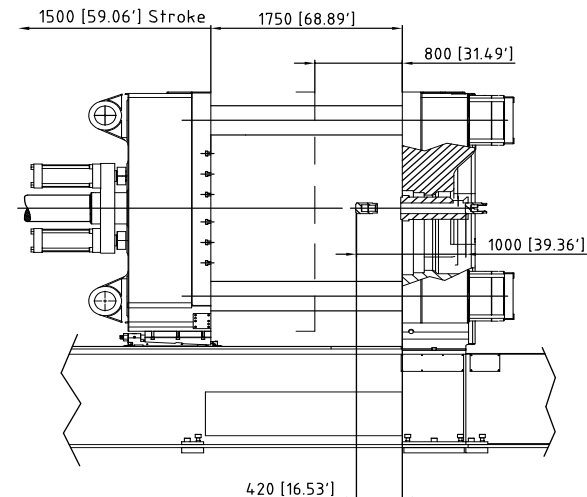
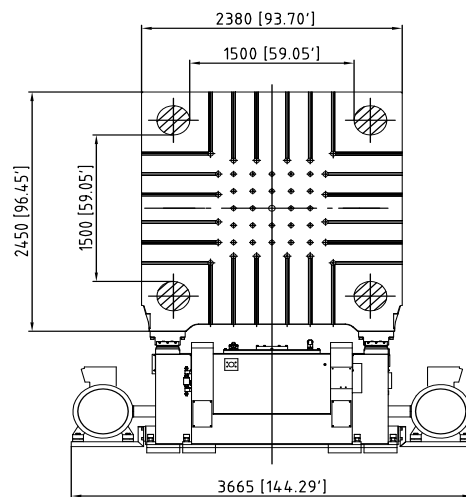
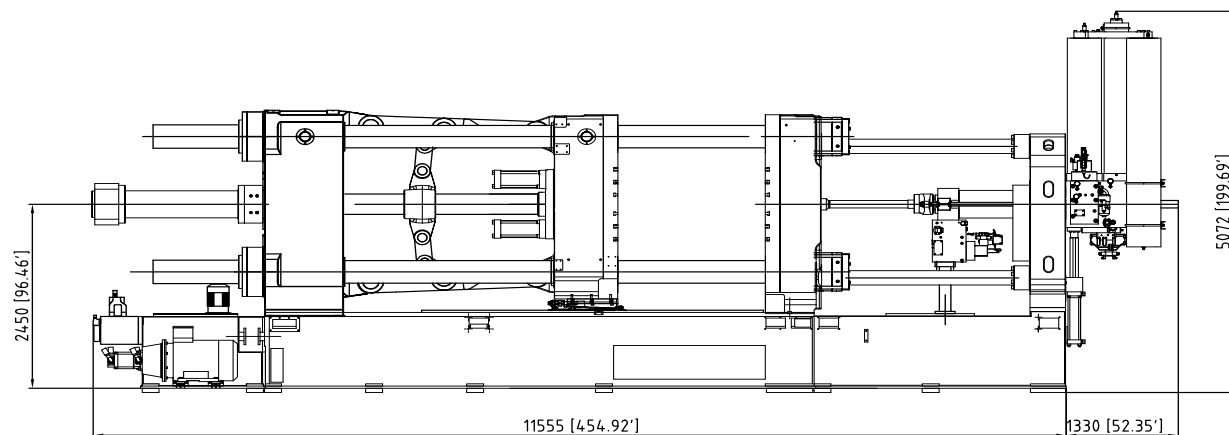

OL 3200 CS



MODEL OL 3200 CS

Clamping force	kN	32.500
Clamping force	Ton	3.313
Injection force with 20 bar counterpressure	kN	1.910
Ejection force	kN	786
Max. die height	mm	1.900
Min. die height	mm	900
Platens dimensions (HxV)	mm	2640x2640
Tie bar spacing	mm	1720x1720
Tie bar diameter	mm	330
Movable platen stroke	mm	1.600
Ejection stroke	mm	350
Max. shot weight (Al alloy)	kg	59
Max. projected area (400 bar on metal)	cm ²	8.282
Dry Cycles (as per DIN 24480)	n/1'	2.1
Pumps motors power	KW	2x90
Machine weight	Ton	205
Machine dimensions (LxWxH)	m	14.5x5.6x5.3

TECHNICAL DATA

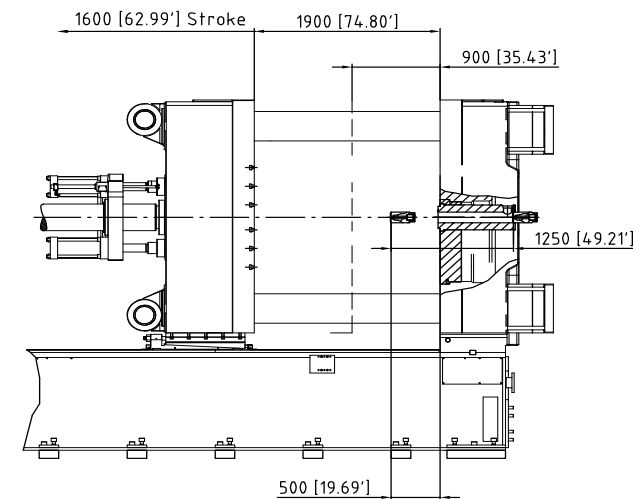
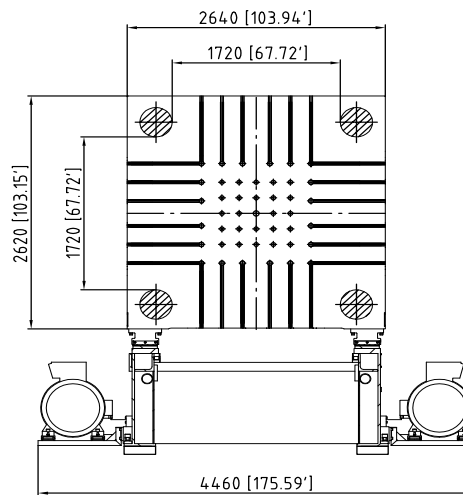
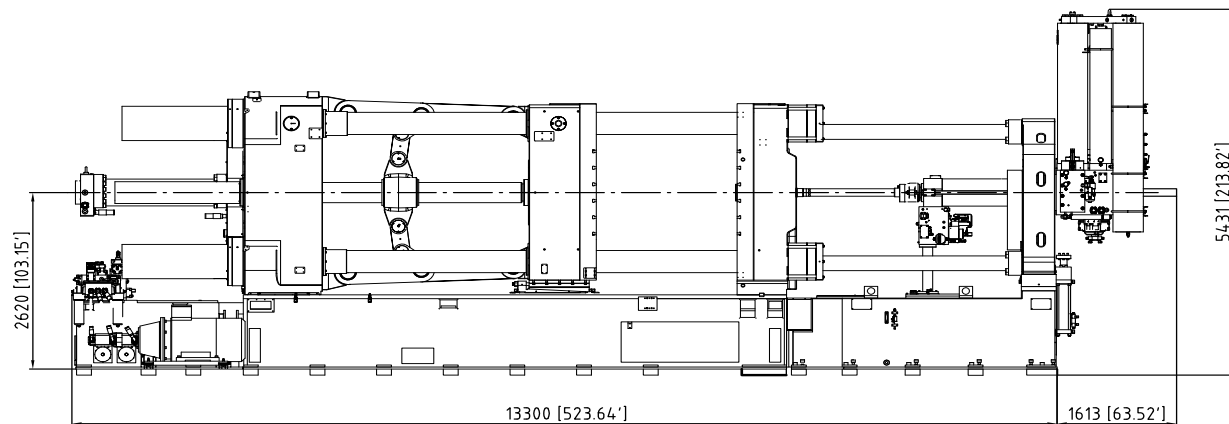

OL 3700 CS



MODEL OL 3700 CS

Clamping force	kN	37.700
Clamping force	Ton	3.843
Injection force with 20 bar counterpressure	kN	2.061
Ejection force	kN	1.100
Max. die height	mm	2.100
Min. die height	mm	1.100
Platens dimensions (HxV)	mm	2840x2840
Tie bar spacing	mm	1770x1770
Tie bar diameter	mm	350
Movable platen stroke	mm	1.700
Ejection stroke	mm	400
Max. shot weight (Al alloy)	kg	79
Max. projected area (400 bar on metal)	cm ²	9.608
Dry Cycles (as per DIN 24480)	n/1'	1.7
Pumps motors power	KW	2x110
Machine weight	Ton	227
Machine dimensions (LxWxH)	m	15.2x5.8x5.6

TECHNICAL DATA

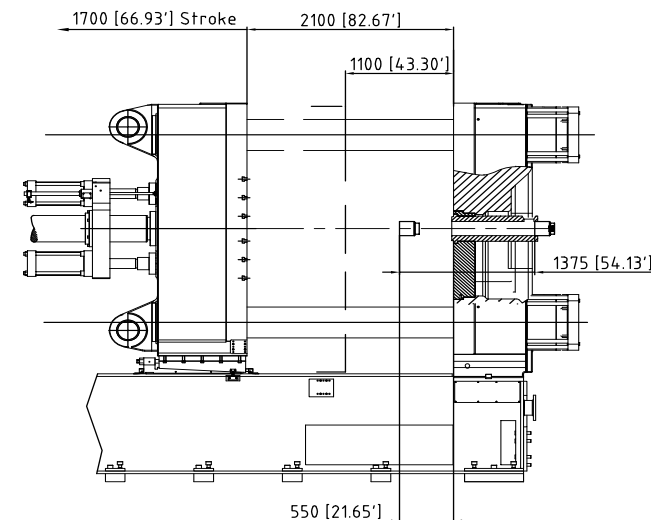
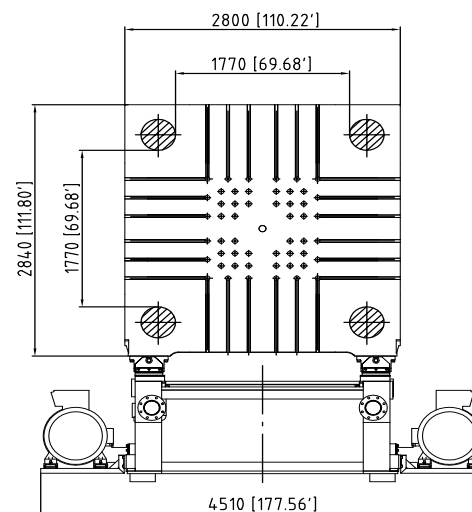
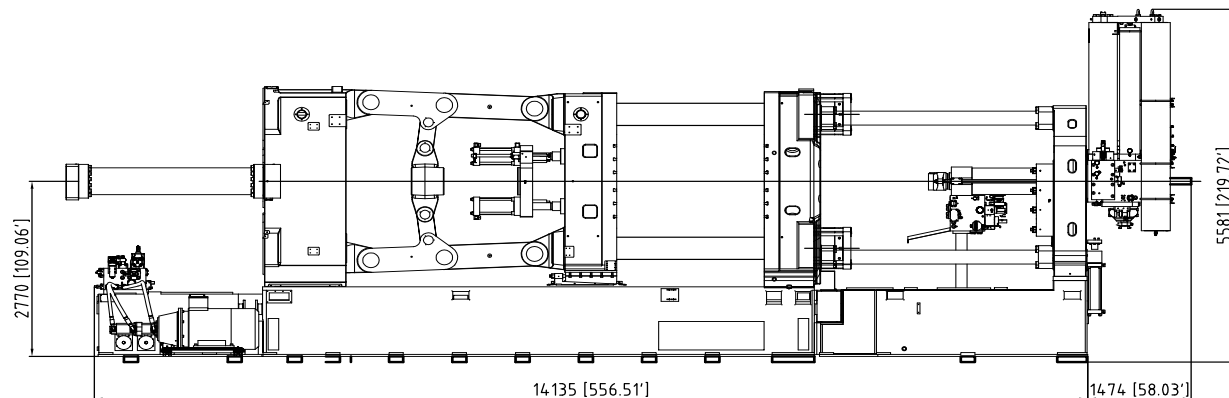

OL 4200 CS



MODEL OL 4200 CS

Clamping force	kN	43.200
Clamping force	Ton	4.404
Injection force with 20 bar counterpressure	kN	2.255
Ejection force	kN	1.100
Max. die height	mm	2.100
Min. die height	mm	1.100
Platens dimensions (HxV)	mm	2900x2900
Tie bar spacing	mm	1850x1850
Tie bar diameter	mm	370
Movable platen stroke	mm	1.800
Ejection stroke	mm	400
Max. shot weight (Al alloy)	kg	84
Max. projected area (400 bar on metal)	cm ²	11.009
Dry Cycles (as per DIN 24480)	n/1'	1.5
Pumps motors power	KW	2x110
Machine weight	Ton	270
Machine dimensions (LxWxH)	m	15.7x5.9x5.7

TECHNICAL DATA

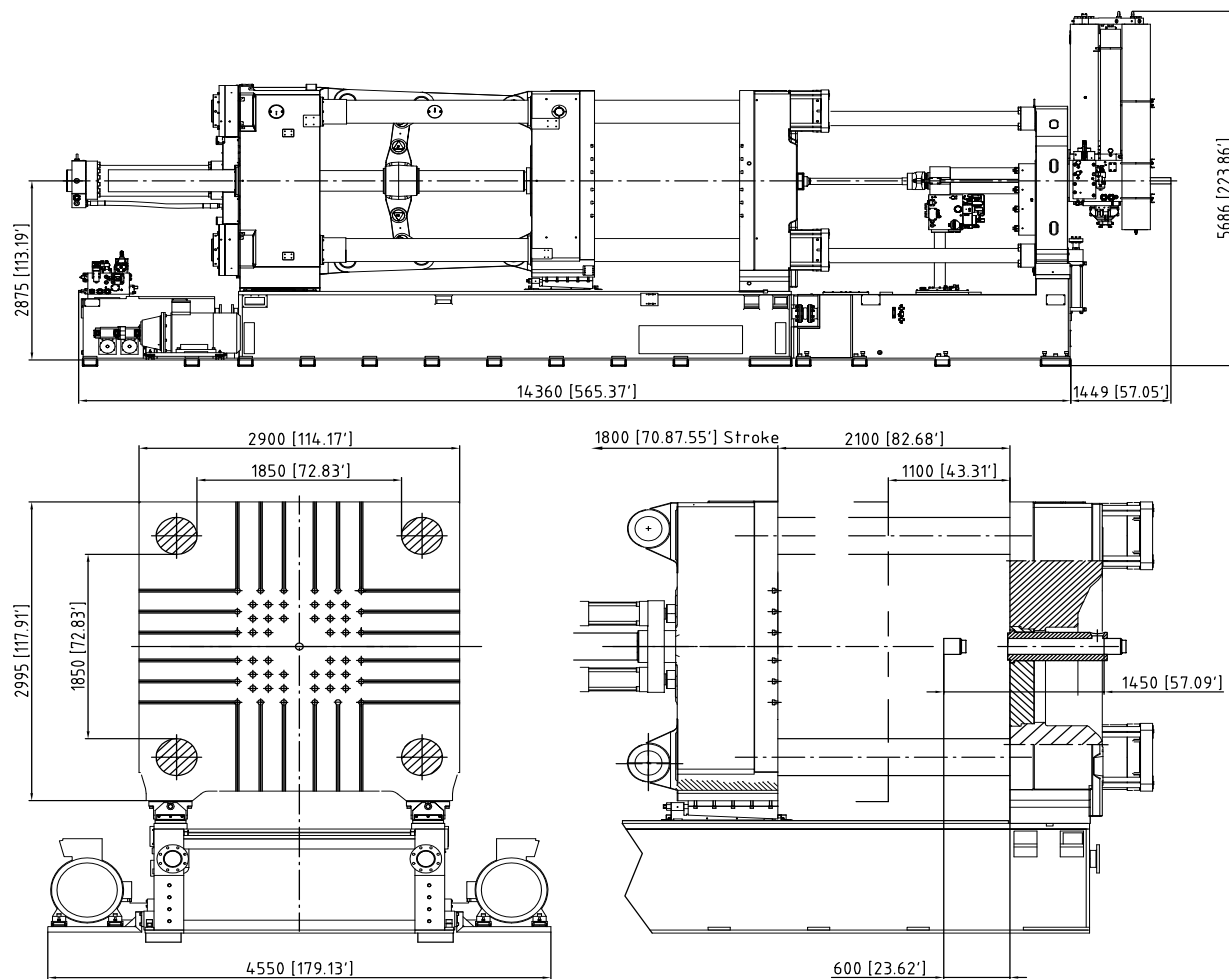

OL 5500 CS



MODEL OL 5500 CS

Clamping force	kN	55.000
Clamping force	Ton	5.607
Injection force with 20 bar counterpressure	kN	3.097
Ejection force	kN	1.100
Max. die height	mm	2.400
Min. die height	mm	1.500
Platens dimensions (HxV)	mm	3.600x3.600
Tie bar spacing	mm	2.300x2.300
Tie bar diameter	mm	450
Movable platen stroke	mm	2.300
Ejection stroke	mm	400
Max. shot weight (Al alloy)	kg	84
Max. projected area (400 bar on metal)	cm ²	14.016
Dry Cycles (as per DIN 24480)	n/1'	1,5
Pumps motors power	KW	4x75
Machine weight	Ton	427
Machine dimensions (LxWxH)	m	19,20x5,22x5,90

TECHNICAL DATA

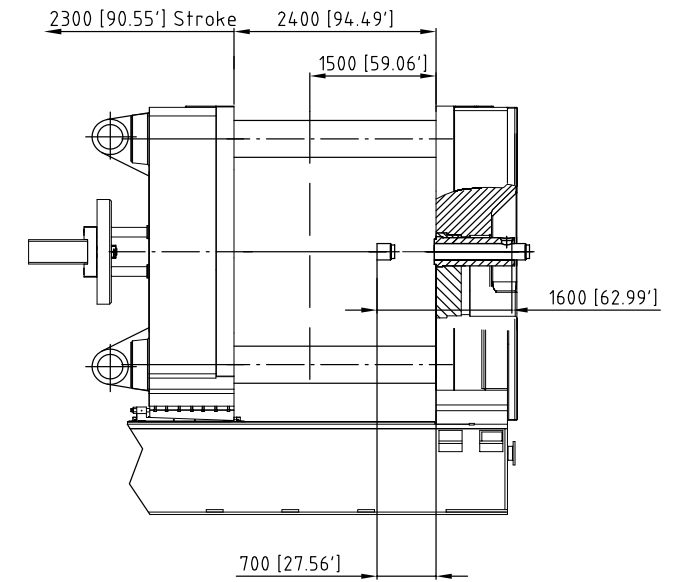
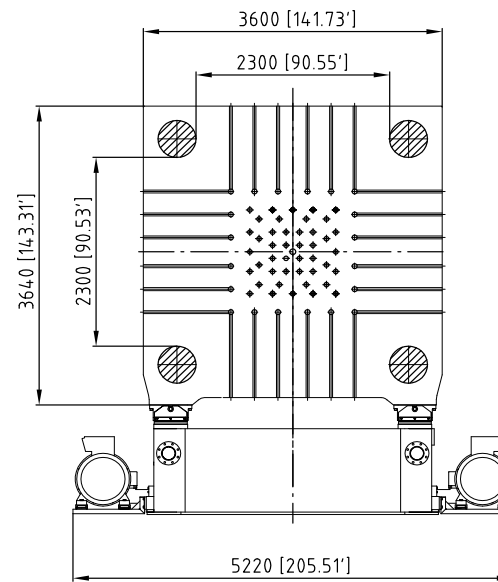
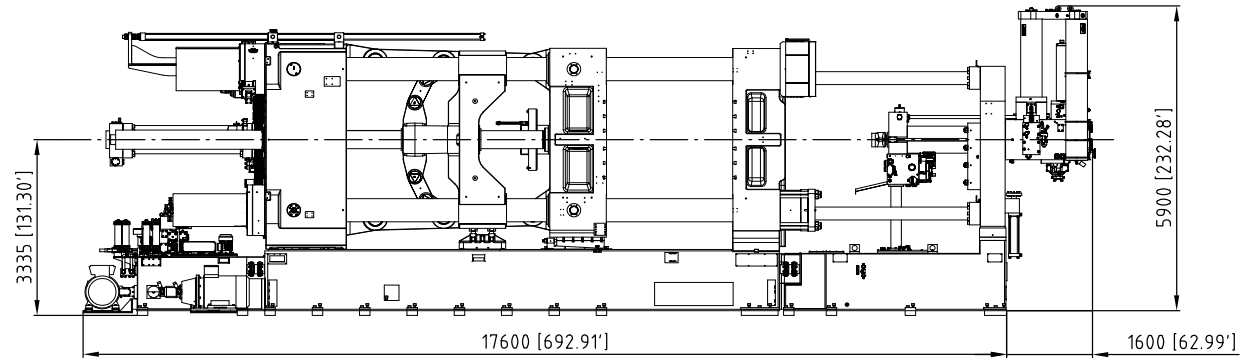

OL 6200 CS



MODEL OL 6200 CS

Clamping force	kN	61.000
Clamping force	Ton	6.218
Injection force with 20 bar counterpressure	kN	3.097
Injection force	kN	3.407
Max. die height	mm	2.500
Min. die height	mm	1.500
Platens dimensions (HxV)	mm	3.700x3.700
Tie bar spacing	mm	2.350x2.350
Tie bar diameter	mm	470
Movable platen stroke	mm	2.300
Ejection stroke	mm	400
Max. shot weight (Al alloy)	kg	104,6
Max. projected area (400 bar on metal)	cm ²	15.545
Dry Cycles (as per DIN 24480)	n/1'	1,3
Pumps motors power	KW	4x90
Machine weight	Ton	440
Machine dimensions (LxWxH)	m	19,5x5,32x5,95

TECHNICAL DATA

